

CLEANFIX R 44-450 High-Speed

Table contents

PDF created on: 10.11.2023 19:56



R44-450 High-Speed

Stieloberteil
Partie supérieure en avant
Top part front side
B 5 / ST 5

Stromlaufplan
Diagramme électrique
Wiring diagram
B 8 / ST 8

Stielversteller
Règlage du manche
Shaft adjuster
B 4 / ST 4

Motor
Moteur
B 1 / ST 1

Elektronik und
Fahrwerk
Electronique et
train de transport
Electronic and
drive axle
B 3 / ST 3

Antriebssteile
Pieces de commande
Driving pieces
B 2a / ST 2a , ab Masch. Nr., à partir de appareils no.
as from machine no. 9213
B 2 / ST 2 , bis Masch. Nr., à des appareils no.
up to machine no.9212

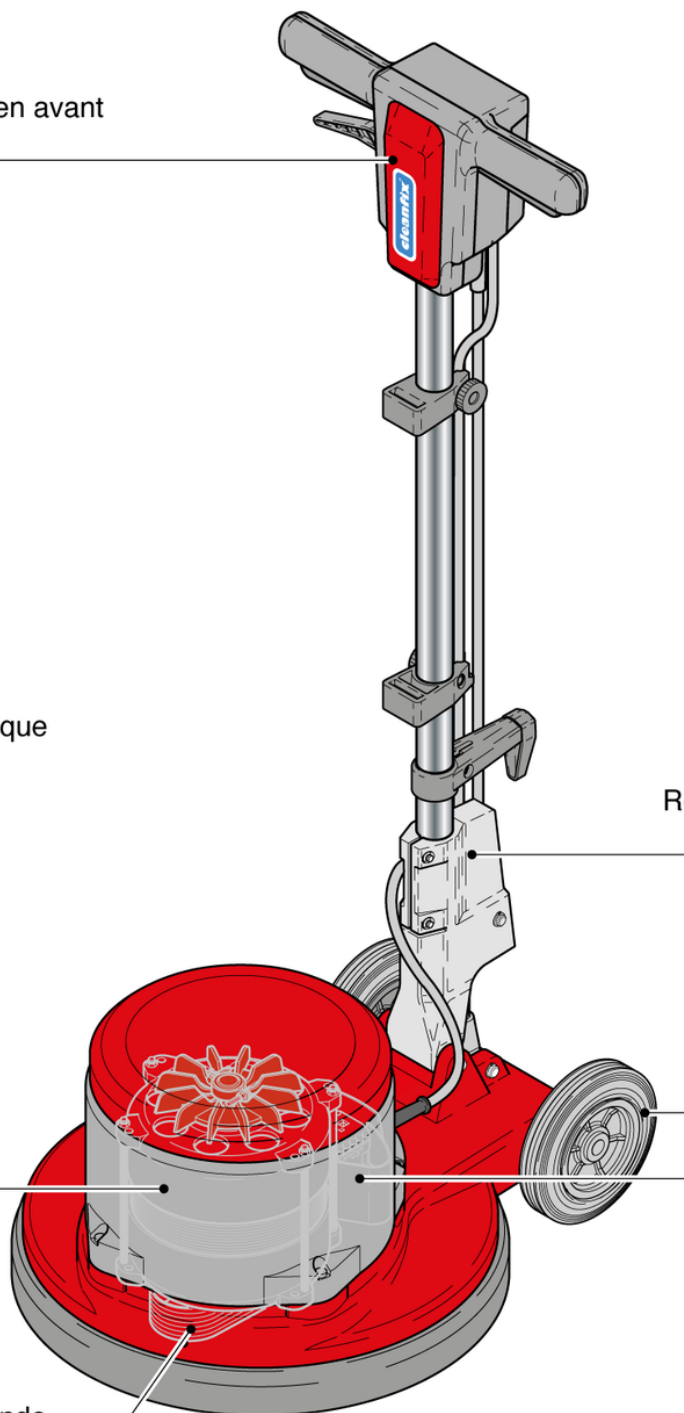

CLEANFIX R 44-450 High-Speed

Motor

PDF created on: 10.11.2023 19:56



R44-450 High-Speed

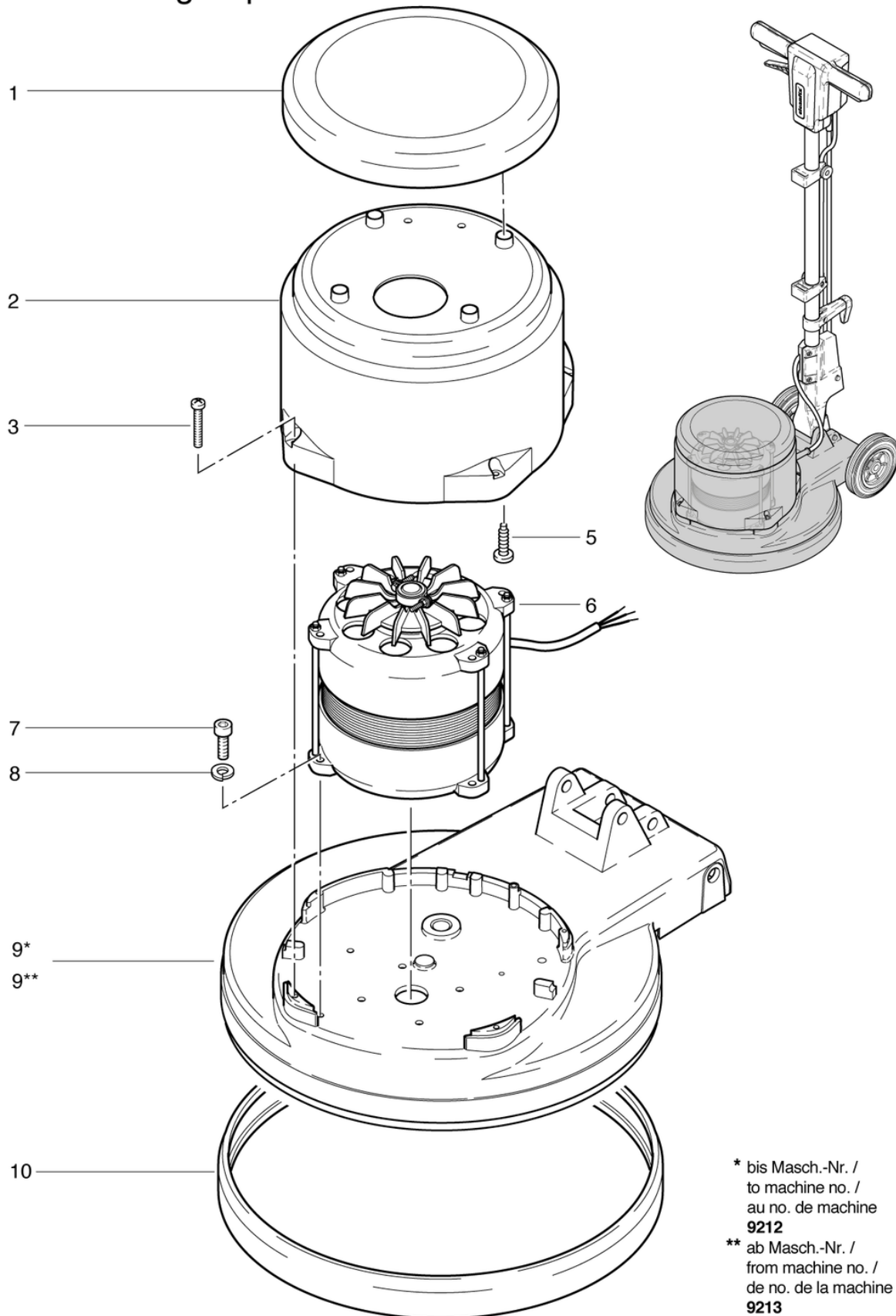

* bis Masch.-Nr. /
to machine no. /
au no. de machine
9212

** ab Masch.-Nr. /
from machine no. /
de no. de la machine
9213

Pos.	Item no.	Spare part
1	741.067	Cover MD red CL
2	741.066	Engine hood MD anthracite gray
3	P476I	Screw DIN 7985 M5 x 30
5	P516P	Screw WN 1452 K40 x 12
6	752.121	Motor
7	P486T	Screw DIN 912 M6 x 25
8	P498U	Ring DIN 127 B M6 6,1/11,8/1,6 A2
9	741.095	Lower housing
9	742.055	Lower Housing
10	742.053	Buffer Ring (USE 741.054)

CLEANFIX R 44-450 High-Speed

Driving pieces from machine No. 9213

PDF created on: 10.11.2023 19:56



R44-450 High-Speed

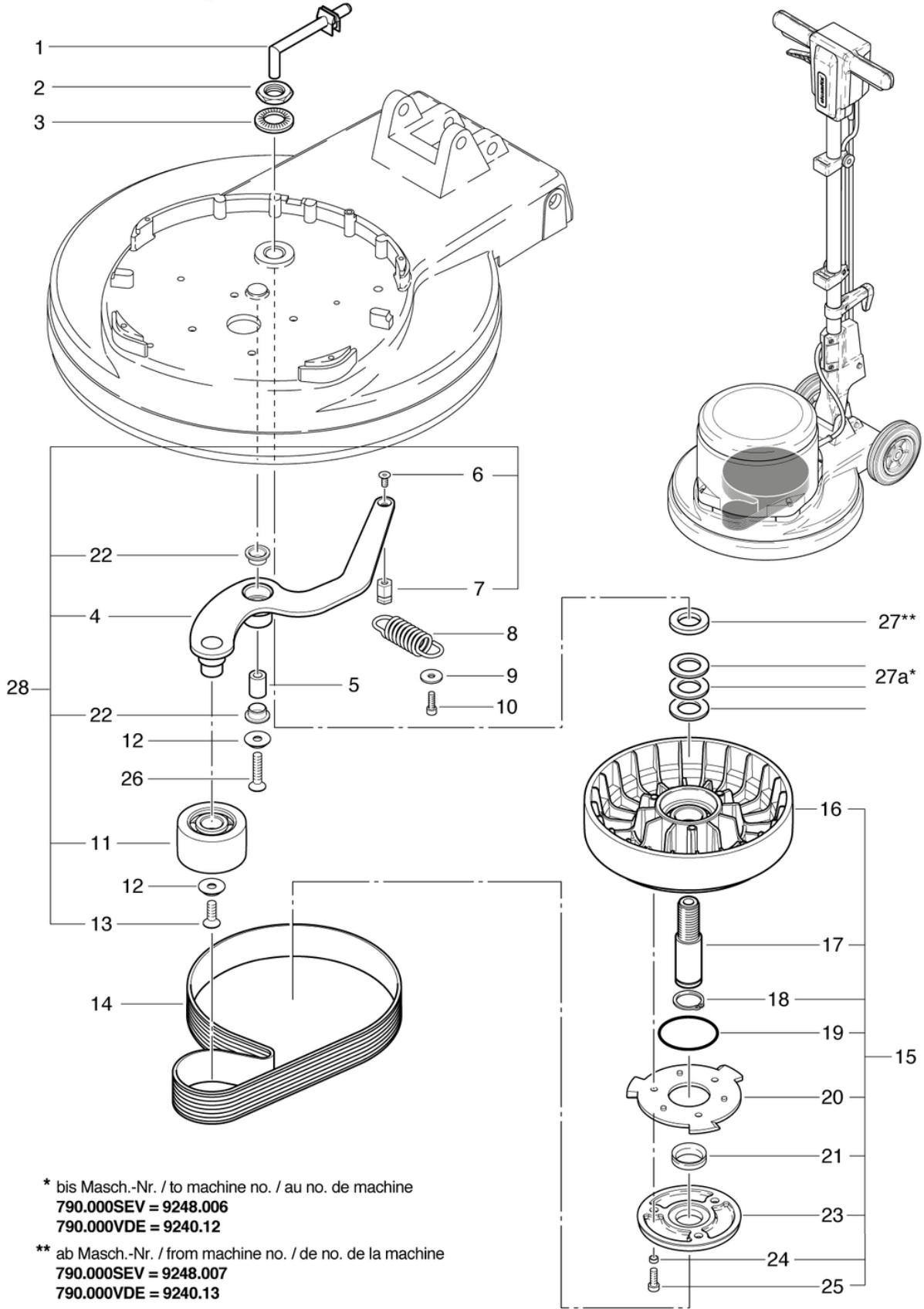

* bis Masch.-Nr. / to machine no. / au no. de machine
790.000SEV = 9248.006
790.000VDE = 9240.12

** ab Masch.-Nr. / from machine no. / de no. de la machine
790.000SEV = 9248.007
790.000VDE = 9240.13

Pos.	Item no.	Spare part
1	741.064	Lye pipe MD anthracite gray
2	P492R	Nut DIN 934 M20 x 1.5 A2
3	P498Q	Shim NFE 25511 M20 20,5/40/4,9
4	726.302	Tension Pulley
5	739.135	Sleeve
6	P487U	Screw DIN 7991 M6 x 12
7	726.303	holder
8	P511I	Tension spring RZ-177MI 3,6 / 25 / 59,4
9	P498I	Washer DIN 522 M5 5,3/20/1,5
10	P484O	Screw DIN7985 M5 x 10
11	726.301	Pulley
12	P500T	Shim SN 213912 M8 25/4,8 A2
13	P480Q	Screw DIN 7991 M8 x 16 A2
14	6390520	Poly-V-belt 15-PJ-864mm Lw
15	741.127	Belt pulley pre-assembled
16	726.130	Belt pulley CL
17	741.125	Main Axle
18	P513D	Ring DIN 471 25/1,2
19	P964A	Ring DIN 3771 55,25/2,62 EPDM
20	742.141	Pad Hub
21	P344	Shaft sealing ring 25x40x3 EPDM/V2A
22	P316X	Plain bearing PBG 151709F
23	742.128	Brush Support
24	742.129	Distance ring \varnothing 8 / 6 x 4
25	P487S	Screw DIN 912 M6 x 20 A2
26	P487R	Screw DIN 7991 M8 x 35
27a	P499W	Rondelle 30 x 1,8
27	430.151	Washer 20 x 32 x 3mm
28	726.300	Belt tension pulley cpl.

CLEANFIX R 44-450 High-Speed

Driving pieces to machine no 9212

PDF created on: 10.11.2023 19:56



R44-450 High-Speed

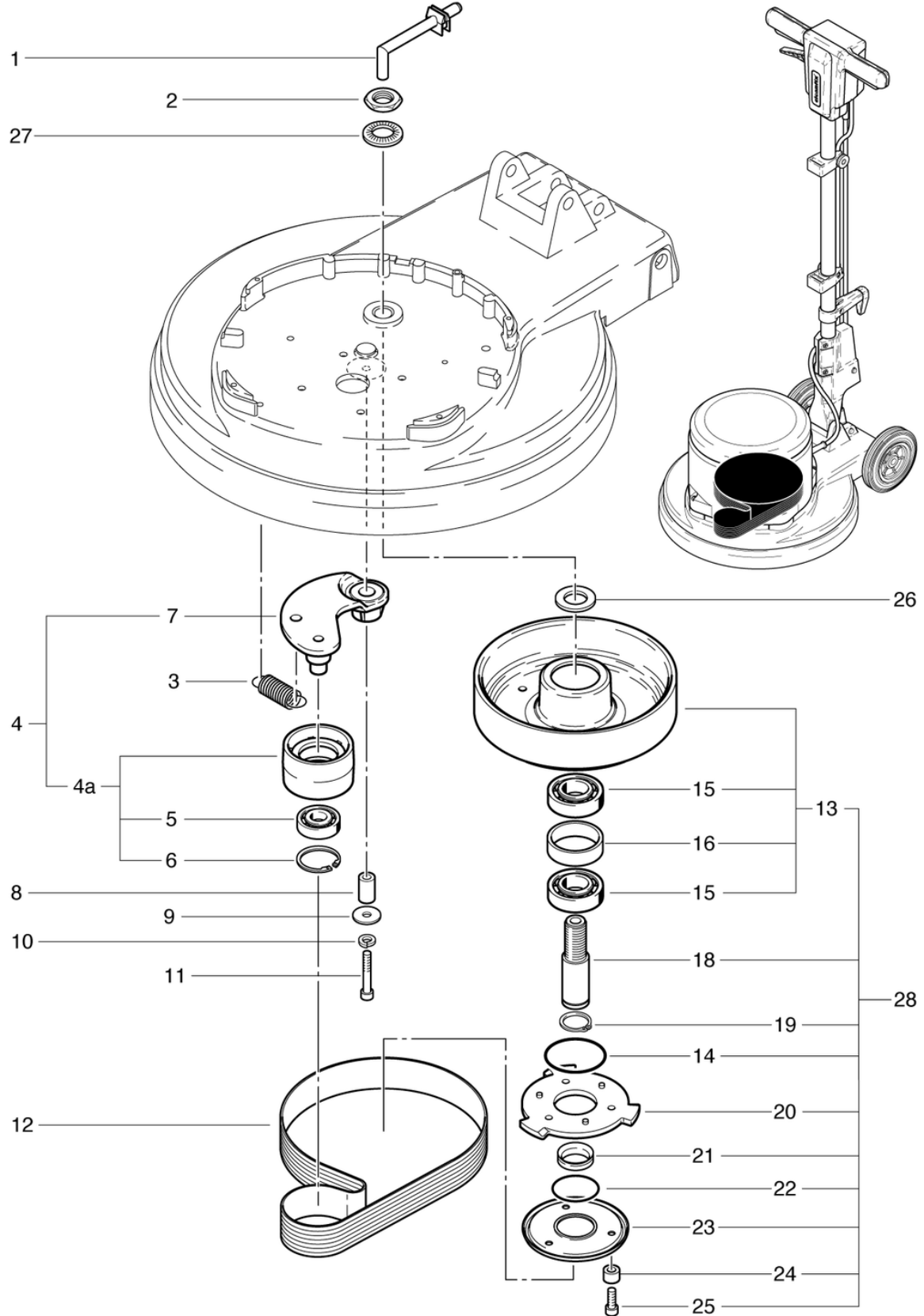

Pos.	Item no.	Spare part
1	741.064	Lye pipe MD anthracite gray
2	P492R	Nut DIN 934 M20 x 1.5 A2
3	635611363	Mainspring 2.8 / 18.5 / 66
4.a	742.116	Tension pulley ø65.2 x 37 cpl.
4	742.100	Belt Tension Pulley
5	P3160	Deep groove ball bearing 6302 2RSR ø42 / 15 x 13
6	P513G	Ring DIN 472 42/1,75
7	742.133	Belt Tension Lever
8	742.135	Distance Ring
9	P496Q	Shim DIN 9021 M8 8,4/24/2
10	P498N	Ring DIN 127 B M8 8,1/14,8/2
11	P487I	Screw DIN 912 M8 x 40
12	6390520	Poly-V-belt 15-PJ-864mm Lw
13	742.130	Belt wheel Type 1
14	P964A	Ring DIN 3771 55,25/2,62 EPDM
15	P316P	Deep groove ball bearing 6205 2RS ø52 / 25 x 15
16	3611851	Spacer ring ø 52 / 45 x 15
18	741.125	Main Axle
19	P513D	Ring DIN 471 25/1,2
20	742.141	Pad Hub
21	P344	Shaft sealing ring 25x40x3 EPDM/V2A
22	P964B	Ring DIN 3771 42,52/2,62 EPDM
23	742.128	Brush Support
24	742.129	Distance ring ø 8 / 6 x 4
25	P487S	Screw DIN 912 M6 x 20 A2
26	430.151	Washer 20 x 32 x 3mm
27	P498Q	Shim NFE 25511 M20 20,5/40/4,9
28	741.126	Belt wheel pre-mounts cpl. including Items 13-25

CLEANFIX R 44-450 High-Speed

Electronic and drive axle

PDF created on: 10.11.2023 19:56



R44-450 High-Speed

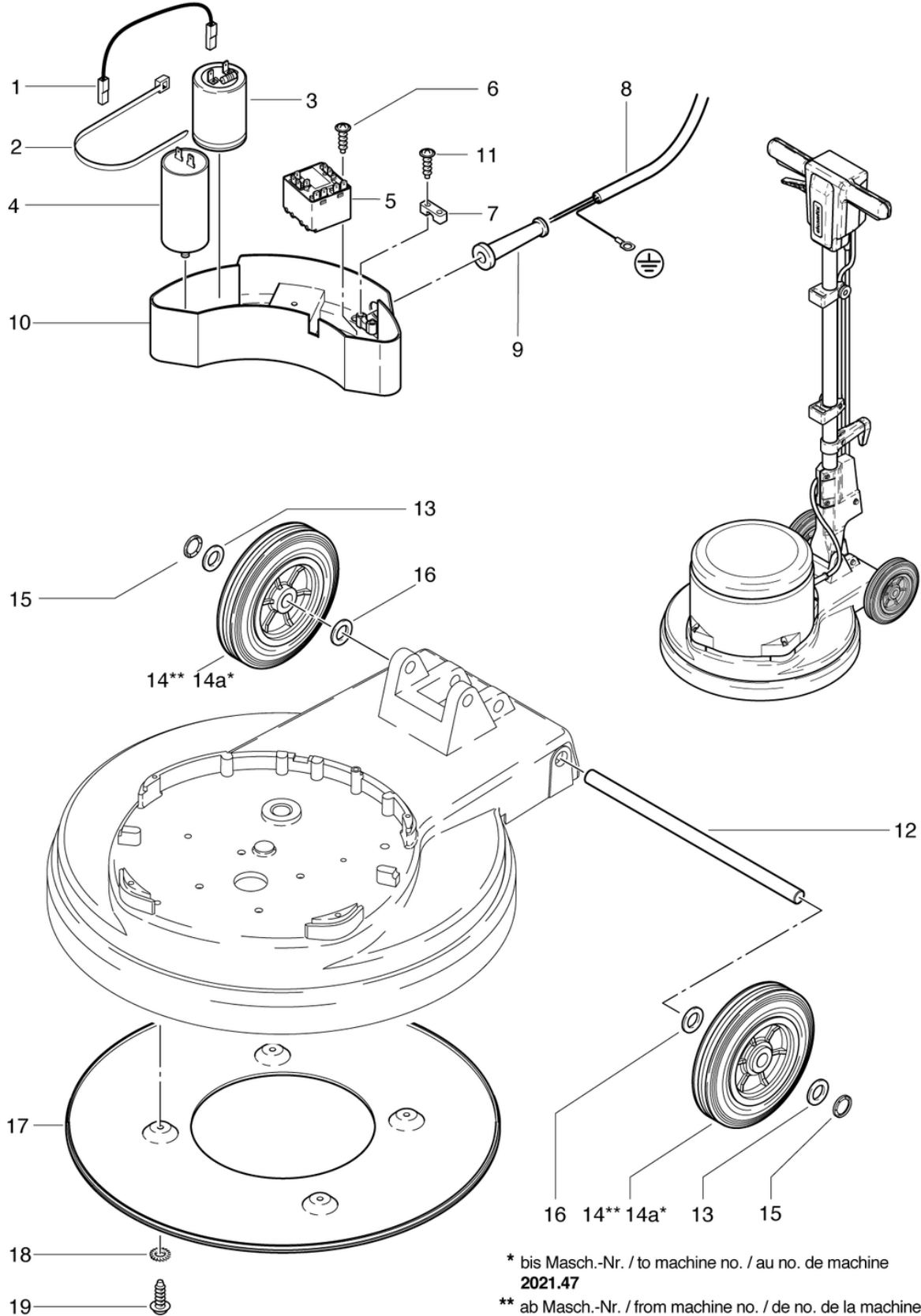

Pos.	Item no.	Spare part
1	742.331	Wiring black
2	P424	Cable tie black 4.8 x 300mm
3	742.328	Capacitor 125 uF, 320 V
4	P385J	Capacitor 25uF,450VAC
5	P350	Motor start relay
6	P516A	Screw WN 1452 K30 x 10 A2
7	4611085	Cable Clamp
8	751.313	Cable with clamp 6mm ² , gray 3x1,5mm ²
9	660011014	R53-1100 Cable Sleeve
10	741.315	Housing
11	P516Q	Screw WN 1452 K50 x 18
12	742.040	Wheel axle
13	P510	Shim DIN 988 16/28/0,5
14a	741.072A	Wheel ø160 x 40mm rework
14	741.072	Wheel ø160 x 40mm
15	P500H	Feather ring M8
16	P496Y	Shim DIN 125 M14 15/28/2,5
17	742.146	Ground
18	P498K	Shim DIN 6798 M6 6,4/11/0,7
19	P483P	Screw BN 1023 M5 x 12

Pos.	Item no.	Spare part
1	742.410L	Shaft Tube
2	742.212L	Drawbar L = 863mm
3	634711031	Compression spring 1 / 6.2 / 55
4	623711022	Guide Sleeve
5	P493K	Nut DIN 985 M6
6	672711018	Axle
7	P499Q	Shim DIN 6799 8/16,3/1
8	P486T	Screw DIN 912 M6 x 25
9	741.260	Shaft adjustment red
10	672711016	Axis \varnothing 12 x 99mm
11	672711017	Axis \varnothing 12 x 82.2mm
12	2711133	Handle adjuster cpl.
13	3711236	Adjustment piece long
14	634711020	Compression spring 2 / 12,2 / 37
15	4711014	Holder
16	3711237	Adjustment piece short
17	672711019	Axle
18	741.270	Adjusting rod 177mm cpl.
19	P496K	Shim DIN 125 A M6 6,4/12/1,6

CLEANFIX R 44-450 High-Speed

Top part front side

PDF created on: 10.11.2023 19:56



R44-450 High-Speed

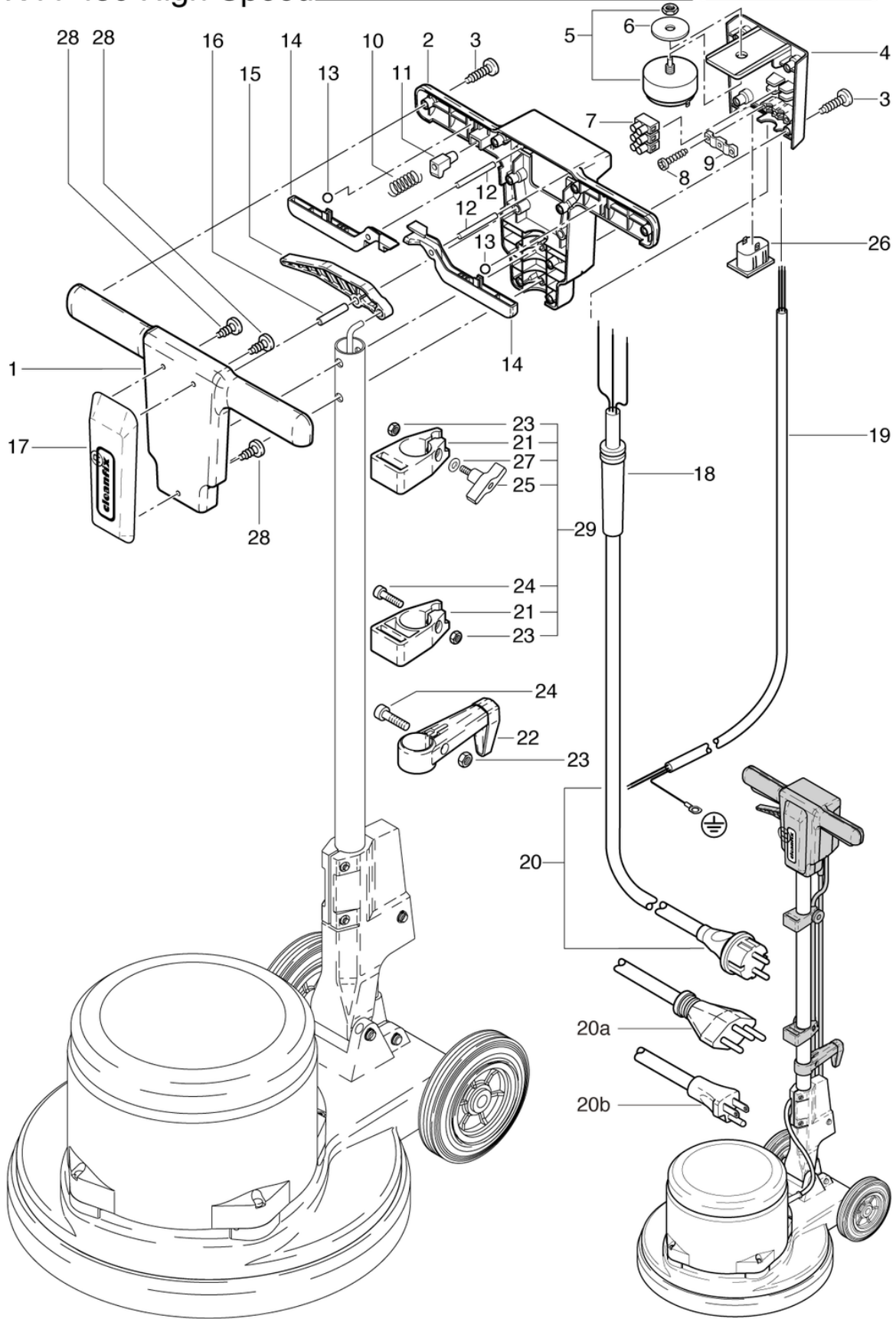

Pos.	Item no.	Spare part
1	741.201	Front Cover Handle
2	741.202	Upper part of handle at the back anthracite gray
3	P515L	Screw WN 1452 K50 x 25 A2
4	741.310	Rear Handle Cover
5	6650454	Switch
6	P496	Shim DIN 9021 M12 13/37/3
7	P383N	Terminal block with DS, 3-pole, 6mm ²
8	P516Q	Screw WN 1452 K50 x 18
9	742.321	Cable clamp
10	742.209	Compression spring VD-090L 0.55 / 6 / 29.2
11	742.208	Button grey anthrazite
12	P512M	Pin ISO 2338 6 x 50 pc vz
13	6440641	Ball DIN 5401 8
14	741.204	Switch
15	741.207	Shaft Adj Lever
16	P512P	Pin ISO 2338 8 x 40 pc vz
17	741.208	Screen, red
18	660011014	R53-1100 Cable Sleeve
19	751.313	Cable with clamp 6mm ² , gray 3x1,5mm ²
20a	65671103901	Mains cable SEV 3 x 1.5mm ² , 12.5m
20b	P289D	Mains cable GB 3 x 1.5mm ² , 15m, gray
20	656711039	Mains cable VDE 3 x 1.5mm ² , 12.5m gray
21	4711231	Solution Tank Holder
22	3711029	Cable holder CL cpl.
23	P490D	Nut DIN 934 M6
24	P486T	Screw DIN 912 M6 x 25
25	P253X	Wing nut Ø48 M6x25
26	P380B	Device socket 2P + E
27	P496K	Shim DIN 125 A M6 6,4/12/1,6
28	P516V	Screw WN 1452 KA25 x 10
29	4711232	Solution tank holder set

CLEANFIX R 44-450 High-Speed

Wiring diagram

PDF created on: 10.11.2023 19:56



R44-450 High-Speed

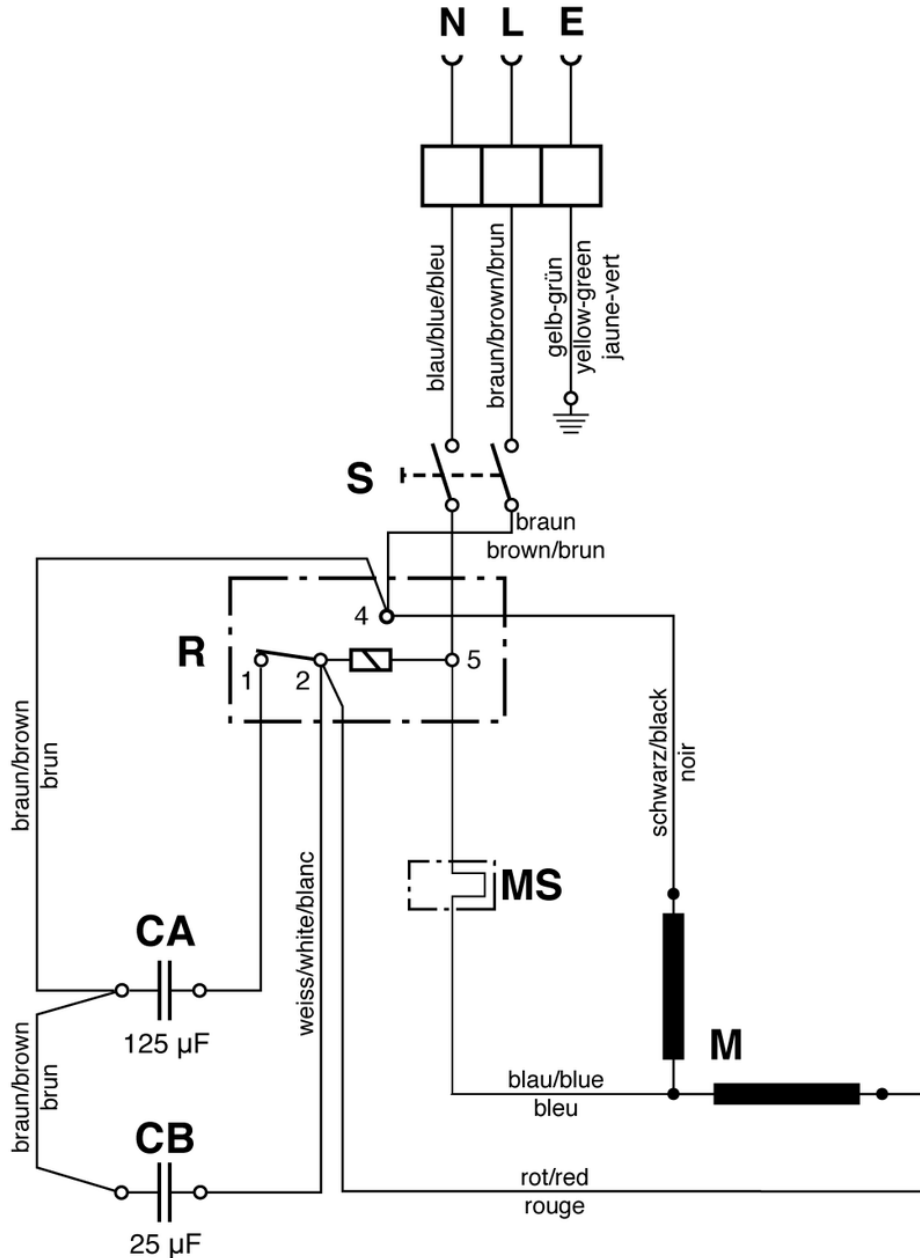

- S = Schalter Bürstmotor / Tumbler switch for motor / Interrupteur pour moteur
- R = Startrelais / Relais / Relais de démarrage
- CA = Anlaufkondensator 125 µF / Capacitor 125 µF / Capaciteur 125 µF
- CB = Betriebskondensator 25 µF / Capacitor 25 µF / Capaciteur 25 µF
- M = Motor / Motor / Moteur
- MS = Motorschutzschalter