

CLEANFIX R53-1100 Ultra High-Speed

Contents

PDF created on: 10.11.2023 20:07



R 53-1100

Stieloberteil
Partie supérieure en avant
Top part front side
B 7 / ST 7

Stromlaufplan
Diagramme électrique
Wiring diagram
B 10 / ST 10

Motor
Moteur
B 1 / ST 1

Elektronik
Electronique
Electronic
B 3 / ST 3

Höhenverstellung und
Pad-Antriebscheibe
Reglage de hauteur et
plateau d'entraînement
Height adjustment and
pad holder
B 6 / ST 6

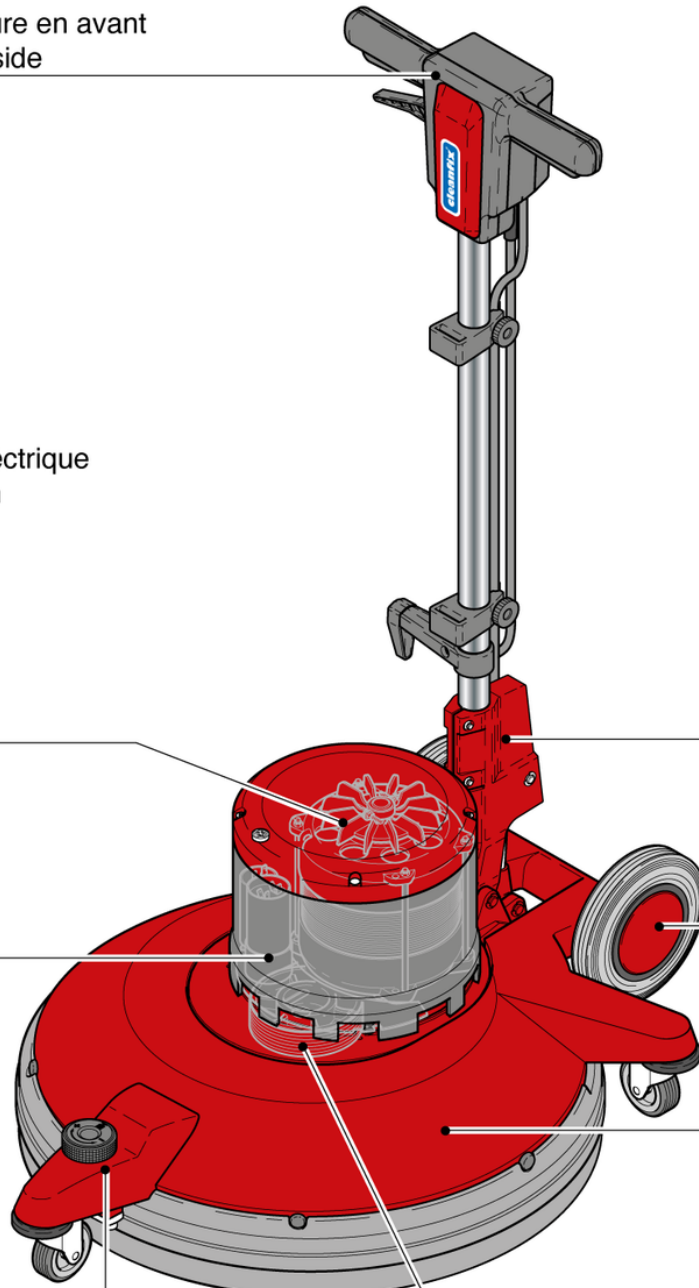

Deichselverstellung
Timon
Shaft
B 4 / ST 4

Gehäuse und
Fahrwerk
Carter et train de
transport
Housing and
drive axle
B 5 / ST 5

Antrieb
Transmission
Drive
B 2 / ST 2

CLEANFIX R53-1100 Ultra High-Speed

Motor

PDF created on: 10.11.2023 20:07



R 53-1100/1500

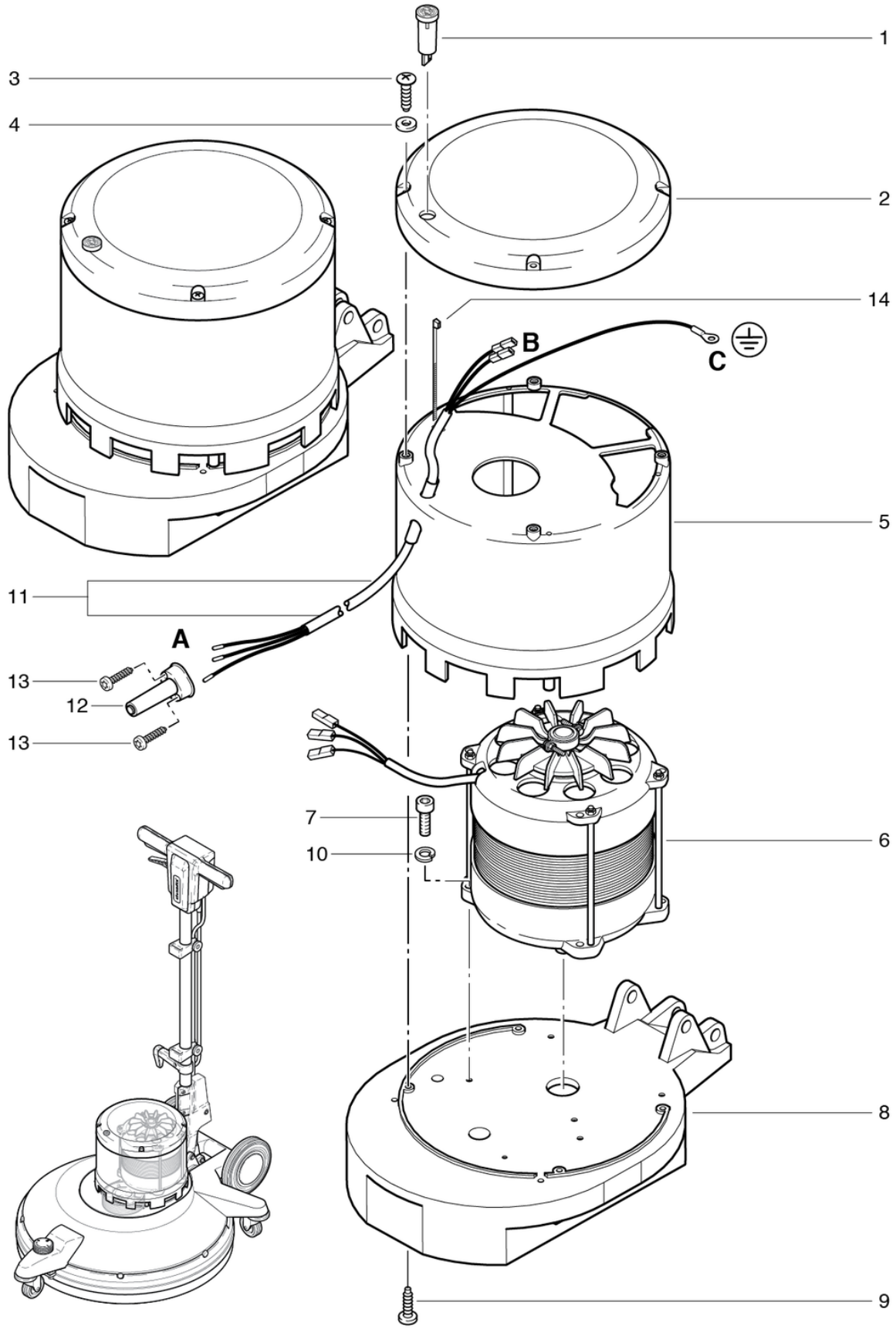

Pos.	Item no.	Spare part
1	P355	Signal light red 250V T120 ° C
2	782.205	Cap
3	P516H	Screw WN 1451 K50 x 16
4	P496G	Shim DIN 9021 M5 5,3/15/1,2
5	782.301	Motor housing
6	785.200	Motor
7	P486T	Screw DIN 912 M6 x 25
8	782.400	Motor support red
9	P515L	Screw WN 1452 K50 x 25 A2
10	P498U	Ring DIN 127 B M6 6,1/11,8/1,6 A2
11	782.310	Motor Cable
12	6605178	Cable security
13	P515X	Screw WN 1452 K40 x 20
14	P421	Cable tie black 2.5 x 98mm

CLEANFIX R53-1100 Ultra High-Speed

Drive

PDF created on: 10.11.2023 20:07



R 53-1100/1500

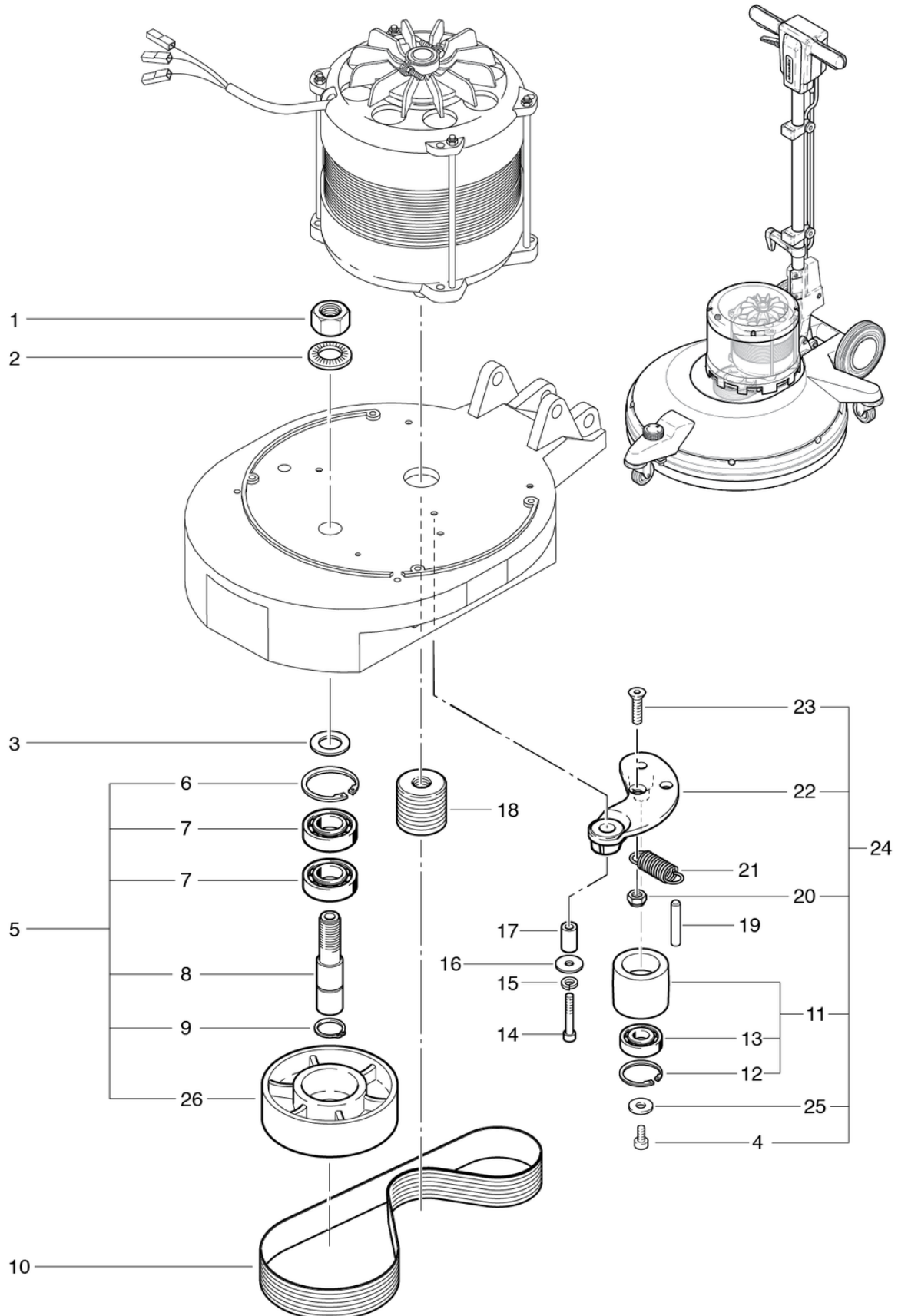

Pos.	Item no.	Spare part
1	P492R	Nut DIN 934 M20 x 1.5 A2
2	P498Q	Shim NFE 25511 M20 20,5/40/4,9
3	430.151	Washer 20 x 32 x 3mm
4	P486Q	Screw DIN 912 M6 x 12 A2
5	782.500	Drive Pulley
6	782.504	Lock ring for bore rule model St 52
7	P316P	Deep groove ball bearing 6205 2RS ø52 / 25 x 15
8	782.501	Main shaft
9	P513D	Ring DIN 471 25/1,2
10	6390521	Poly-V-belt 15-PJ-660mm Lw
11	782.602	Idler complete
12	782.603	Ring
13	P315L	Deep groove ball bearing 6202 2RS ø35 / 15 x 11
14	P487T	Screw DIN 912 M8 x 45 A2 with schaft
15	P498N	Ring DIN 127 B M8 8,1/14,8/2
16	P496Q	Shim DIN 9021 M8 8,4/24/2
17	742.135	Distance Ring
18	3711245	Motorpouile
19	P512M	Pin ISO 2338 6 x 50 pc vz
20	P492H	Nut DIN 985 M8 St galvanized
21	782.203	Belt tensioner
22	742.133	Belt Tension Lever
23	P487R	Screw DIN 7991 M8 x 35
24	782.600	Belt Tension Pulley Complete
25	P496L	Shim DIN 9021 M6 6,4/18/1,6
26	782.503	Drive pulley

CLEANFIX R53-1100 Ultra High-Speed

Electronic

PDF created on: 10.11.2023 20:07



R 53-1100

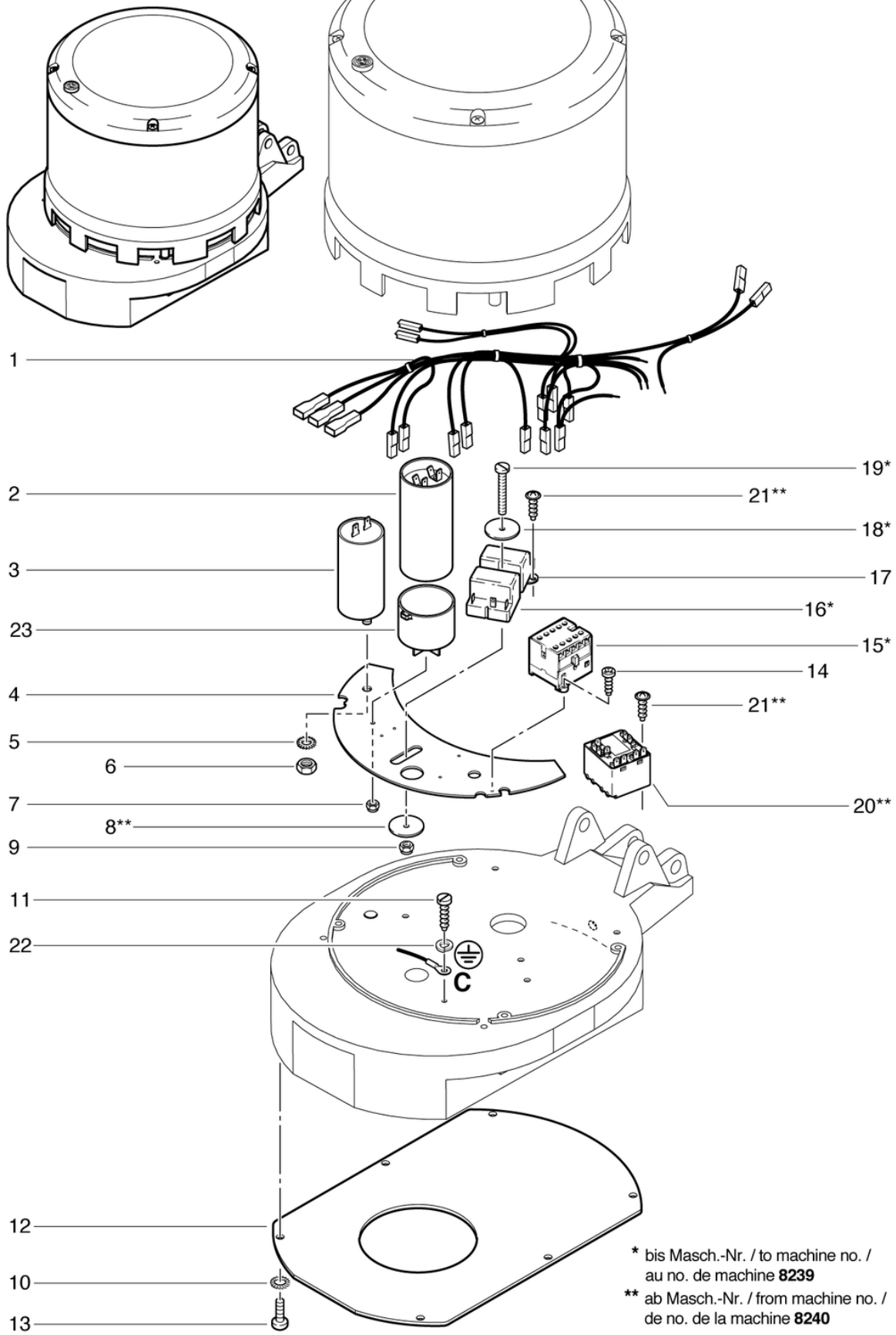

* bis Masch.-Nr. / to machine no. /
au no. de machine **8239**

** ab Masch.-Nr. / from machine no. /
de no. de la machine **8240**

Pos.	Item no.	Spare part
1	782.101	Wiring harness 12 pieces
2	782.307	Capacitor 156uf R53-1100
3	P385J	Capacitor 25uF,450VAC
4	790.351	Reinforcement piece
5	P498G	Shim DIN 6798 M8 8,4/15/0,8
6	P490E	Nut DIN 934 M8
7	P492G	Nut DIN 985 M5 St galvanized
8	P510L	Washer DIN 522 M6 6,4/25/1,5 A2
9	P493D	Stopp-nut DIN 985 M4 A2
10	P498D	Washer DIN 6798 M5 5,1/9/0,5 A2
11	P478B	Screw DIN 84 M4 x 8 Ms
12	4711268	Cover
13	P475L	Screw DIN 7985 M5 x 12 A4
14	P516Q	Screw WN 1452 K50 x 18
15	P352	Engine start relay VK4-T WE
16	6630434	Relay R44-450 2CR105-262
17	420.331A	Relay ER4 10.2 / 8.40A.702
18	P510H	Washer M5 x 20 x 1,5 up to machine no. 8239
19	P475X	ScrewM4 x 45up to machine no. 8239
20	P350	Motor start relay
21	P516A	Screw WN 1452 K30 x 10 A2
22	P498C	Ring DIN 127 B M4 4,1/7,6/0,9
23	741.316	Capacitor Holder

CLEANFIX R53-1100 Ultra High-Speed Shaft

PDF created on: 10.11.2023 20:07



R 53-1100/1500

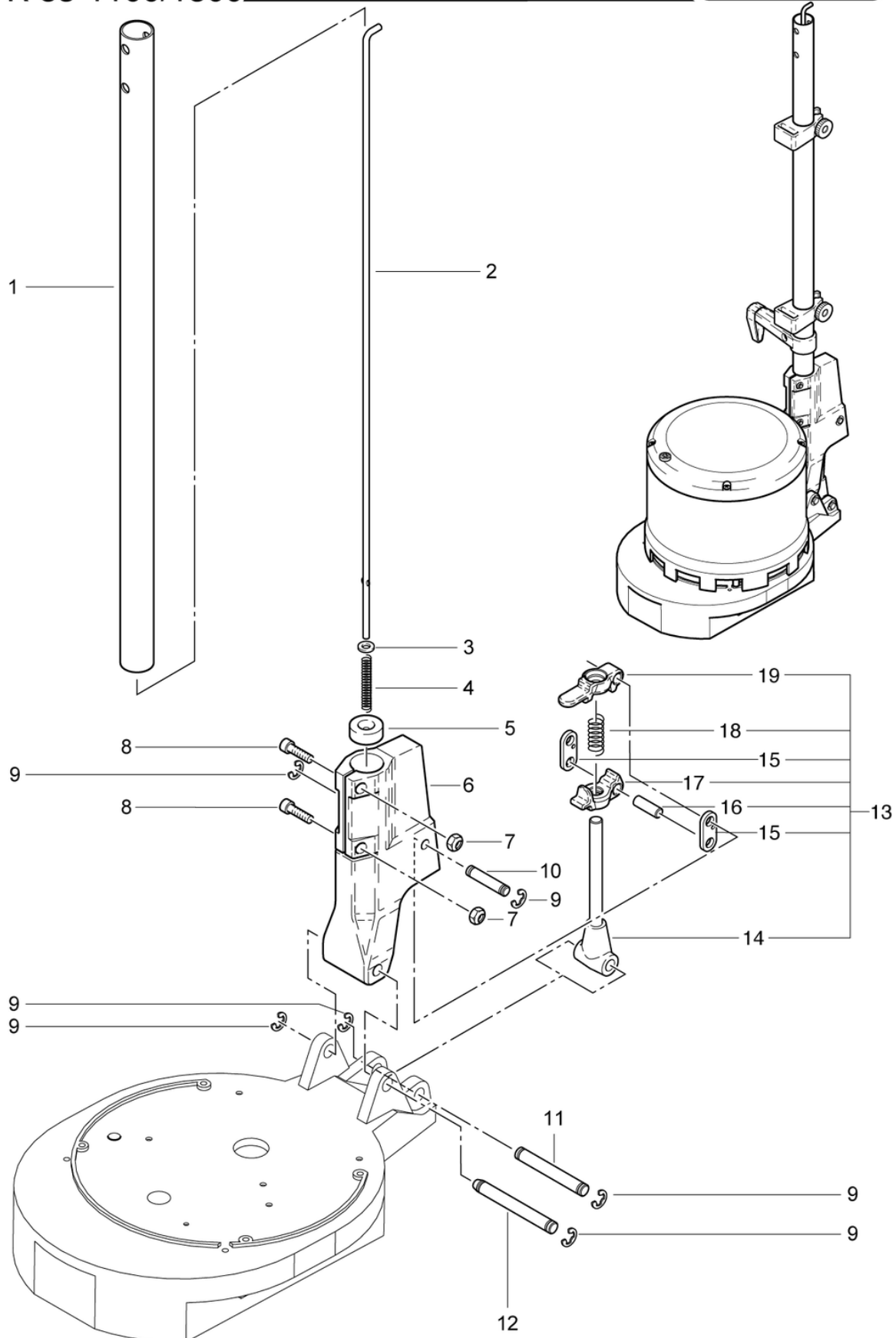

Pos.	Item no.	Spare part
1	742.410L	Shaft Tube
2	742.212L	Drawbar L = 863mm
3	P496K	Shim DIN 125 A M6 6,4/12/1,6
4	634711031	Compression spring 1 / 6.2 / 55
5	623711022	Guide Sleeve
6	741.260	Shaft adjustment red
7	P493K	Nut DIN 985 M6
8	P486T	Screw DIN 912 M6 x 25
9	P499Q	Shim DIN 6799 8/16,3/1
10	672711018	Axle
11	672711181	Axle Ø 12x74 mm
12	672711280	Axle ø12 x 94mm
13	2711133	Handle adjuster cpl.
14	741.270	Adjusting rod 177mm cpl.
15	4711014	Holder
16	672711019	Axle
17	3711237	Adjustment piece short
18	634711020	Compression spring 2 / 12,2 / 37
19	3711236	Adjustment piece long

CLEANFIX R53-1100 Ultra High-Speed

Housing and drive axle

PDF created on: 10.11.2023 20:07



R 53-1100/1500

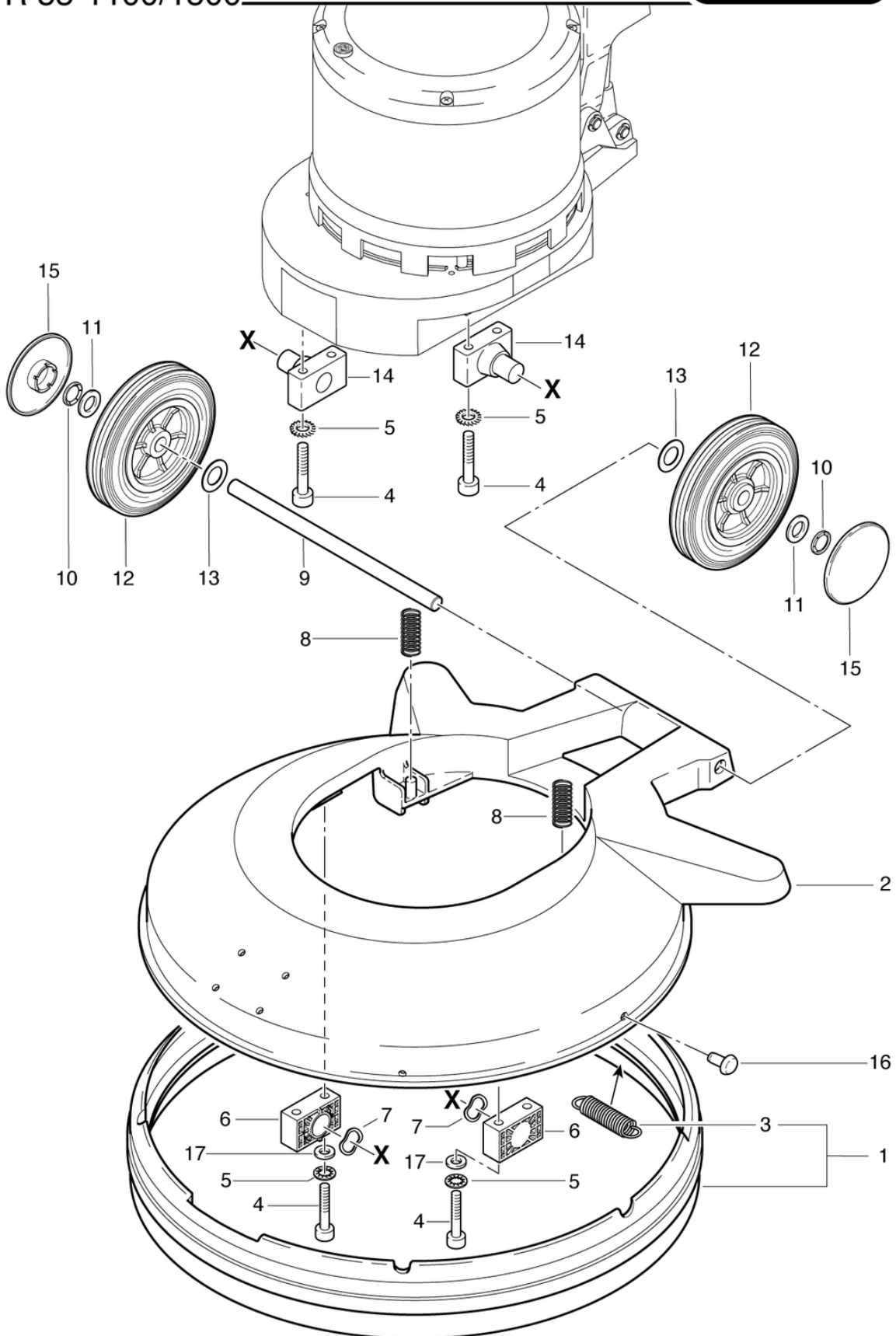

Pos.	Item no.	Spare part
1	789.120	Impact protection cpl.
2	3711239	Machine housing red
3	635008043	coil spring
4	P487E	Washer DIN 9021 M5 5.3/15/1.2 A2
5	P499E	Shim DIN 6798 M8 8,4/15/0,8 A2
6	4711352	Bearing block
7	P498Z	Shim 20,1/25,4/0,2
8	6345201	Compression spring VD-306 3.2 / 23.2 / 74
9	782.040	Axle
10	P500M	Ring Starlock 15 A2
11	P510	Shim DIN 988 16/28/0,5
12	741.074	Wheel ø140 x 40/50mm
13	P496Y	Shim DIN 125 M14 15/28/2,5
14	3711281	Bearing block with shaft
15	741.076	Wheel Cover
16	P070D	Hood clamp knob ø14 / 6 x 18 black
17	P496P	Washer DIN 125 A M8 8,4/16/1,6 A2

CLEANFIX R53-1100 Ultra High-Speed

Height adjustment and pad holder

PDF created on: 10.11.2023 20:07



R 53-1100/1500

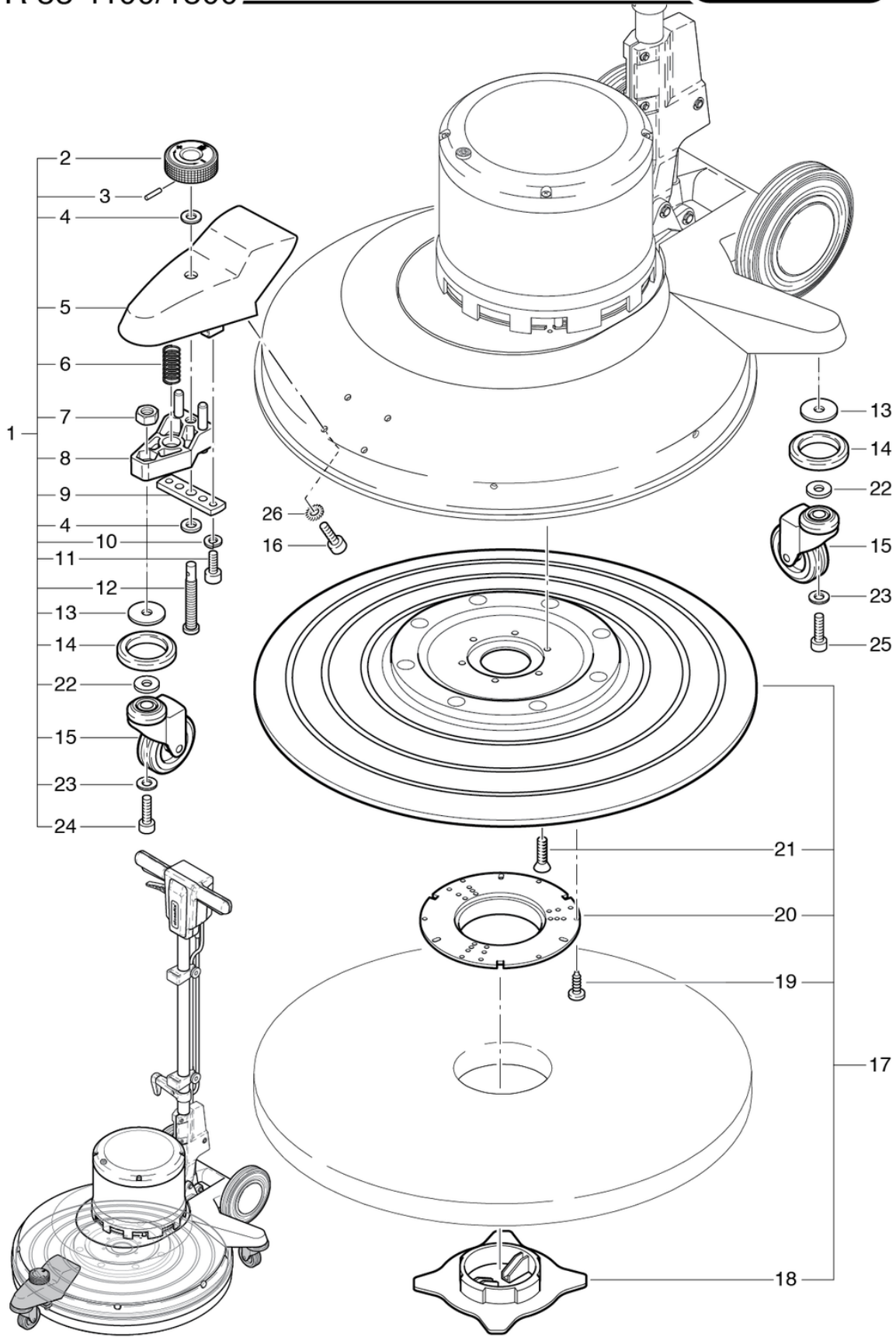

Pos.	Item no.	Spare part
1	2711368	Castor Holder Complete
2	P253A	Cord handle Ø50 x 33 / 8H9
3	P512V	Pin ISO 8752 3 x 20 A2
4	P510A	Shim DIN 125 A M10 10,5/20/2 PA6.6
5	3711261	Wheel housing red
6	6345110	Compression spring 1,8 / 16/40
7	P492Q	Nut DIN 985 M10
8	3711262	Adjusting piece
9	3711263	Guide Plate
10	P498U	Ring DIN 127 B M6 6,1/11,8/1,6 A2
11	P486P	Screw DIN 912 M6 x 20
12	672711265	Special screw
13	4711264	Washer
14	780.129	Ring
15	6415352	Castor Wheel 315/50mm
16	P486O	Screw DIN 912 M6 x 18
17	6925310	Drive Plate UHS 483mm
18	6925311	Centre Grip
19	P516C	Screw WN 1452 K40 x 16
20	6925312	Carrier
21	P480H	Screw DIN 965 M6 x 20 A2
22	P498R	Shim DIN 522 M10 10,5/25/2
23	P498O	Shim DIN 6798 A M10 10,5/18/0,9
24	P487HA	Screw DIN 912 M10 x 35 A2
25	P487K	Screw DIN 912 M10 x 25
26	P498J	Shim DIN 6797 M6 6,4/11/0,7 A2

CLEANFIX R53-1100 Ultra High-Speed

Top part front side

PDF created on: 10.11.2023 20:07



R 53-1100/1500

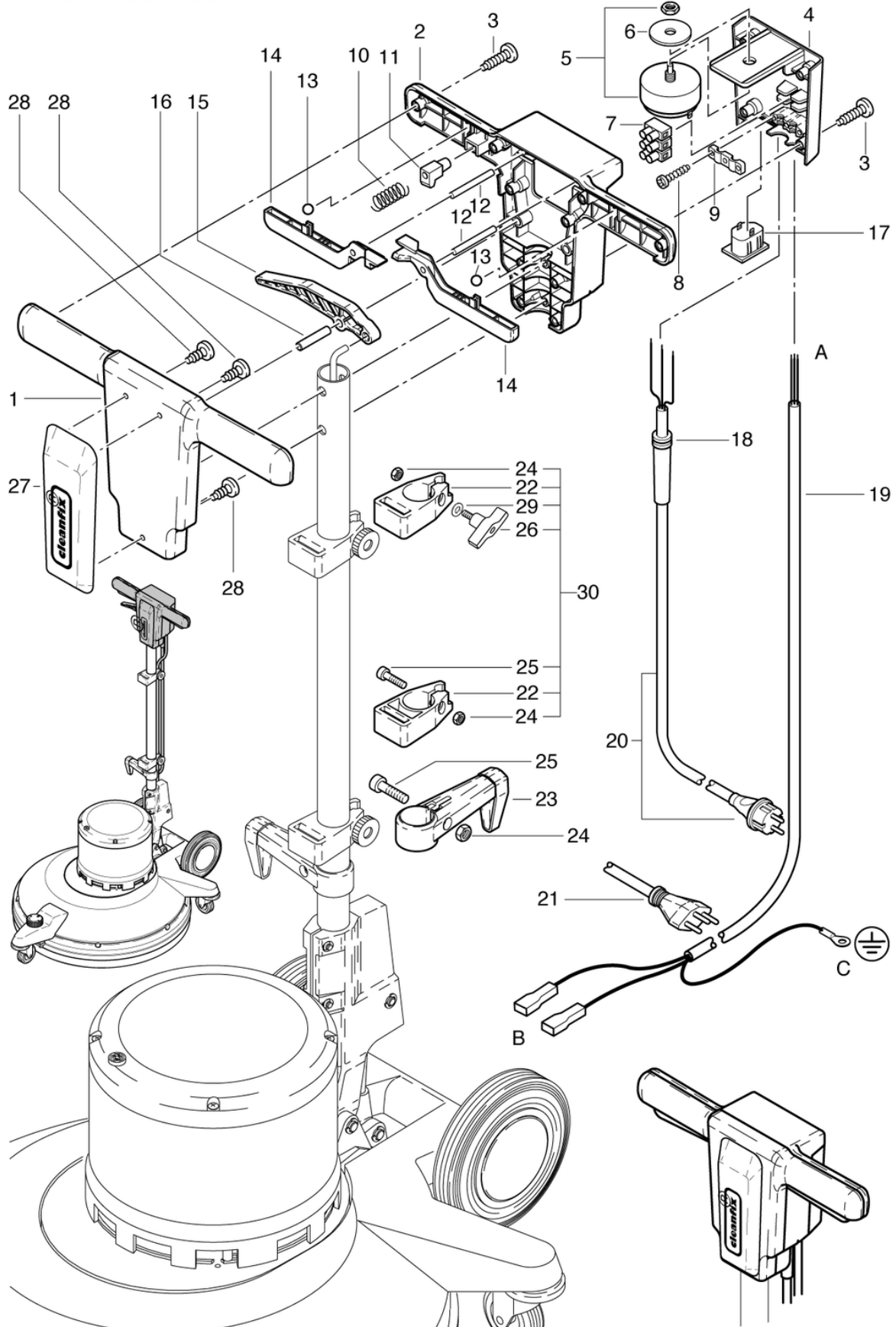

Pos.	Item no.	Spare part
1	741.201	Front Cover Handle
2	741.202	Upper part of handle at the back anthracite gray
3	P515L	Screw WN 1452 K50 x 25 A2
4	741.310	Rear Handle Cover
5	6650454	Switch
6	P496	Shim DIN 9021 M12 13/37/3
7	P383N	Terminal block with DS, 3-pole, 6mm ²
8	P516Q	Screw WN 1452 K50 x 18
9	742.321	Cable clamp
10	742.209	Compression spring VD-090L 0.55 / 6 / 29.2
11	742.208	Button grey anthracite
12	P512M	Pin ISO 2338 6 x 50 pc vz
13	6440641	Ball DIN 5401 8
14	741.204	Switch
15	741.207	Shaft Adj Lever
16	P512P	Pin ISO 2338 8 x 40 pc vz
17	P380B	Device socket 2P + E
18	660011014	R53-1100 Cable Sleeve
19	782.310	Motor Cable
20	656020155	Mains cable 20 m VDE
21	65602015501	Mains cable 20 m SEV
22	4711231	Solution Tank Holder
23	3711029	Cable holder CL cpl.
24	P490D	Nut DIN 934 M6
25	P486T	Screw DIN 912 M6 x 25
26	P253X	Wing nut Ø48 M6x25
27	741.208	Screen, red
28	P516V	Screw WN 1452 KA25 x 10
29	P496K	Shim DIN 125 A M6 6,4/12/1,6
30	4711232	Solution tank holder set

CLEANFIX R53-1100 Ultra High-Speed

Wiring diagram

PDF created on: 10.11.2023 20:07



R 53-1100

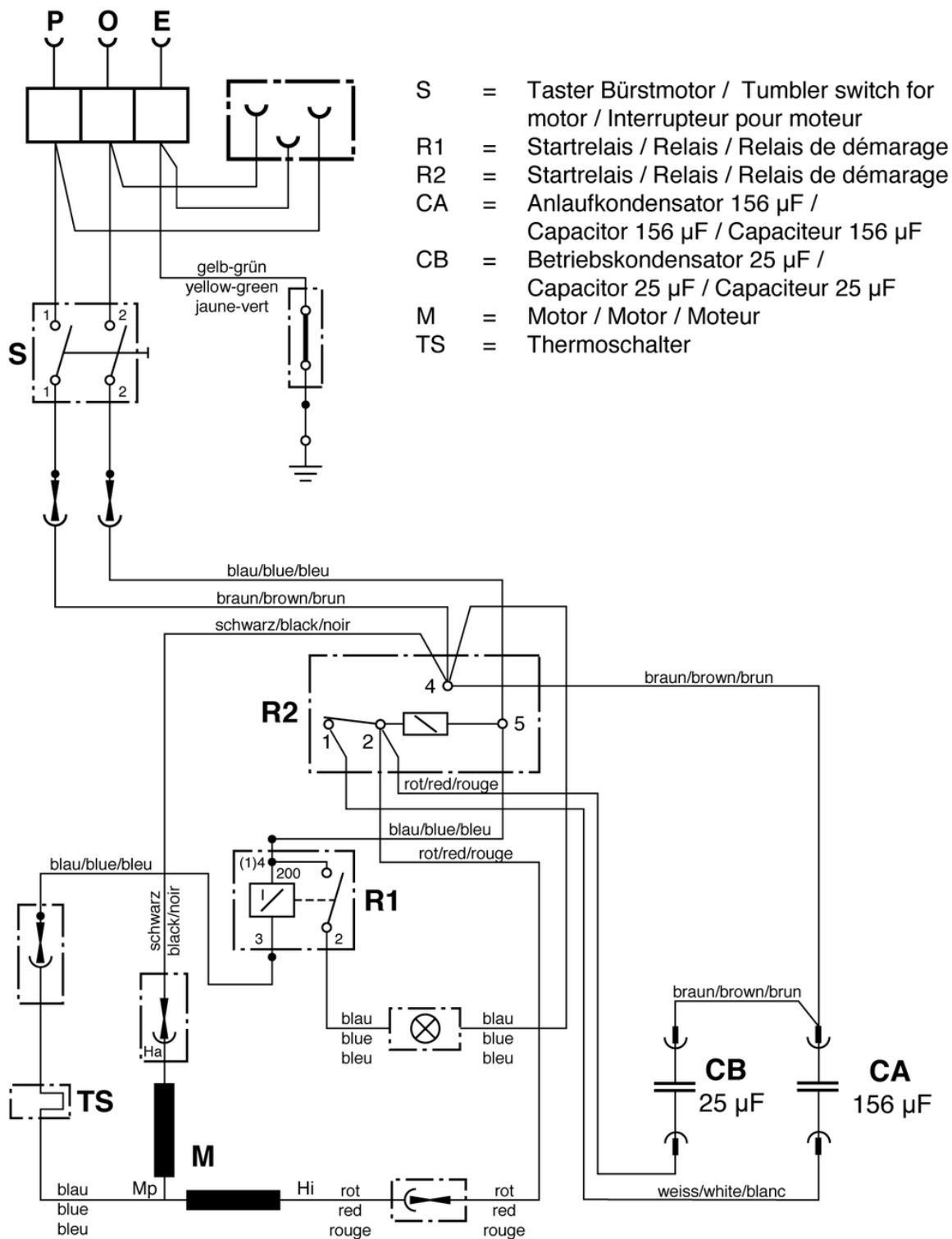

(Stromlaufplan R 43 / R 53-1100, 230-240V / 50 Hz, ab Masch.-Nr. 8240)
 (Wiring diagram R 43 / R 53-1100, 230-240V / 50 Hz, from machine no. 8240)
 (Diagramme électrique R 43 / R 53-1100, 230-240V / 50 Hz, de no. de la machine 8240)